



ACO DRAIN - HEXALINE 2.0

CAIXA INSPECÇÃO P/HEXALINE 2.0 126MM H138 A15 NEGRO



#¿Nombre?

Artigo: 00319560

Caixa de inspecção e ligação L-T-X ACO HEXALINE 2.0, em Polipropileno, para ligação com canais HEXALINE 2.0 com grelha tipo Brickslot, classe de carga A15 de acordo com a norma EN1433, com grelha registrável e saída vertical DN/OD 110. Comprimento 126 mm, altura exterior 138 mm e largura exterior 126 mm. Cor preto. Peso: 0,2 kg.

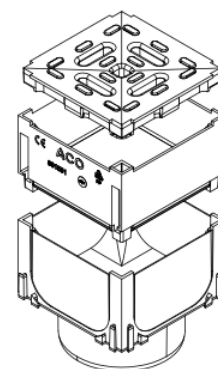
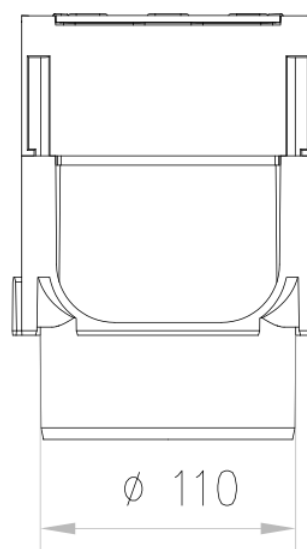
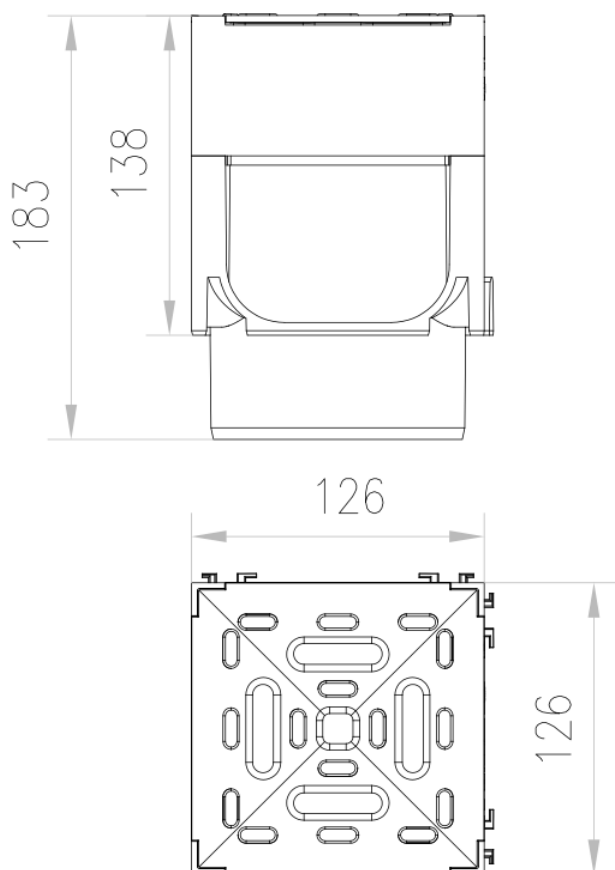

Dimensões:

Modelo	HEXALINE 2.0
Comprimento (mm)	126
Largura ext. (mm)	126
Altura ext. (mm)	138
Peso (Kg)	0,2
Área de absorção grelha (cm ² /m)	117
Classe de carga	A15

