

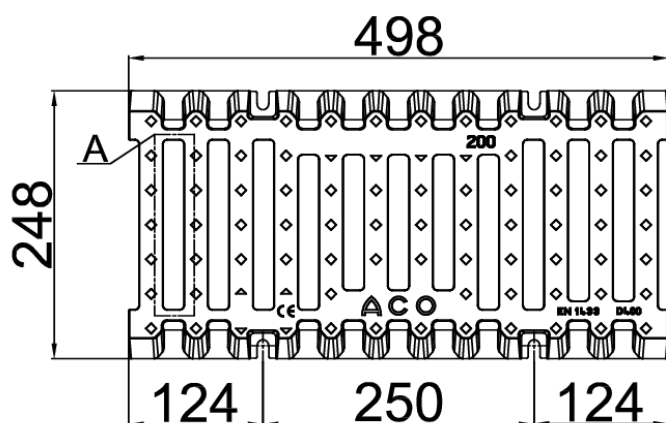

Grelha passarela em ferro fundido, de classe de carga D400 de acordo com a norma EN1433, para canais de drenagem ACO XTRALINE G/B 200. Com sistema de fixação por parafusos. Área de absorção de 552 cm<sup>2</sup>/m. Comprimento total de 498 mm, altura exterior 25 mm, altura exterior total 65 mm e largura exterior 248 mm. Peso: 11,50 kg.

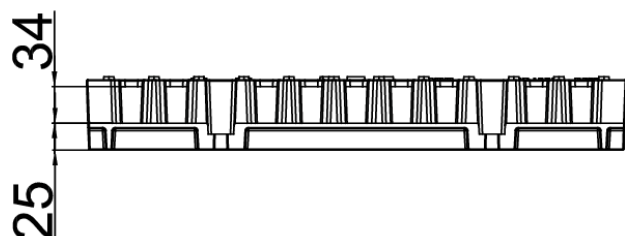
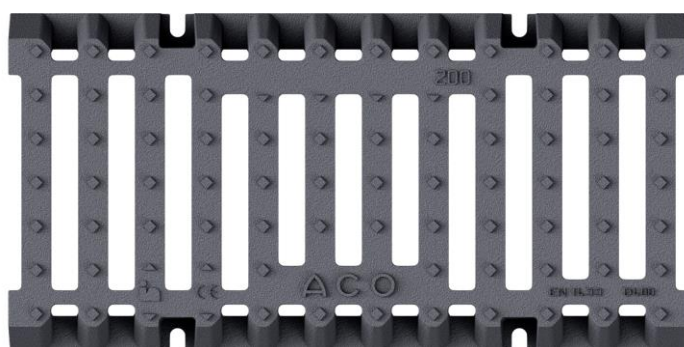
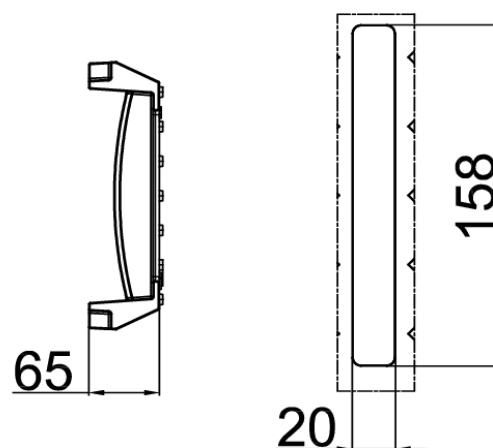

Detalle A (2:1)

**Dimensões:**

Modelo	XTRALINE G/B 200
Comprimento (mm)	498
Largura (mm)	248
Altura ext. (mm)	25
Peso (kg)	11,50
Área de absorção de grelha (cm <sup>2</sup> /m)	552
Classe de carga	D400
Altura ext. Total (mm)	65

